



# Cambridge International AS & A Level

CANDIDATE  
NAME

CENTRE  
NUMBER

|  |  |  |  |  |
|--|--|--|--|--|
|  |  |  |  |  |
|--|--|--|--|--|

CANDIDATE  
NUMBER

|  |  |  |  |
|--|--|--|--|
|  |  |  |  |
|--|--|--|--|



**BIOLOGY**

**9700/33**

Paper 3 Advanced Practical Skills 1

**February/March 2022**

**2 hours**

You must answer on the question paper.

You will need: The materials and apparatus listed in the confidential instructions

## INSTRUCTIONS

- Answer **all** questions.
- Use a black or dark blue pen. You may use an HB pencil for any diagrams or graphs.
- Write your name, centre number and candidate number in the boxes at the top of the page.
- Write your answer to each question in the space provided.
- Do **not** use an erasable pen or correction fluid.
- Do **not** write on any bar codes.
- You may use a calculator.
- You should show all your working and use appropriate units.

## INFORMATION

- The total mark for this paper is 40.
- The number of marks for each question or part question is shown in brackets [ ].

| For Examiner's Use |  |
|--------------------|--|
| 1                  |  |
| 2                  |  |
| <b>Total</b>       |  |

This document has **20** pages. Any blank pages are indicated.

1 You will investigate the water potential of potato cells.

When pieces of potato are put into a sucrose solution, water will move by osmosis into and out of the potato cells. The overall direction of water movement depends on the difference between the water potential of the potato cells and the water potential of the sucrose solution.

- If the overall movement of water is out of the potato cells, the sucrose solution will become less concentrated.
- If the overall movement of water is into the potato cells, the sucrose solution will become more concentrated.

Fig. 1.1 shows how the change in concentration of the sucrose solution after 15 minutes can be assessed. A blue dye is added to the sucrose solution around the potato pieces at the end of the 15 minutes. The blue dye does not affect the concentration of the sucrose solution. After mixing, a drop of the blue sucrose solution is added to the original sucrose solution in a separate test-tube. The movement of the blue drop is then observed.

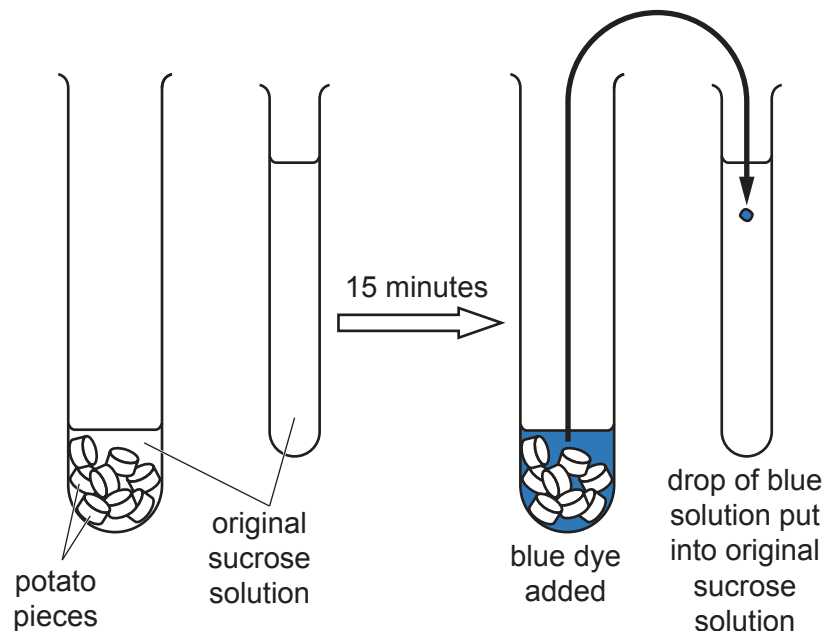

Fig. 1.1

- If the sucrose solution has become less concentrated, then the density of the sucrose solution will have decreased.
- If the sucrose solution has become more concentrated, then the density of the sucrose solution will have increased.

- (a) (i) When two solutions of different density are added to one another without mixing, the denser solution will sink to the bottom and the less dense solution will rise to the top.

Complete Fig. 1.2 by drawing an arrow on each test-tube, as shown in the key, to predict how you expect the drop of blue solution to move.

drop of blue solution is **less** concentrated than the concentration of the original sucrose solution

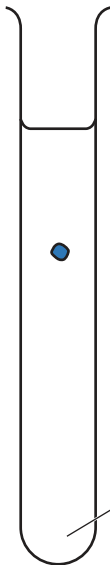

original sucrose solution

drop of blue solution is **more** concentrated than the concentration of the original sucrose solution

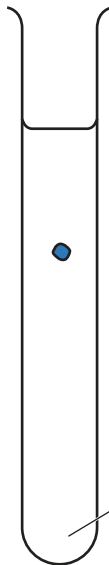

original sucrose solution

drop of blue solution is the **same** concentration as the concentration of the original sucrose solution

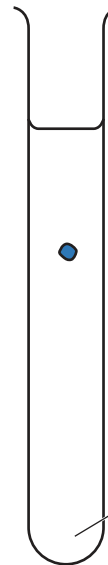

original sucrose solution

**key:**

- ↑ drop of blue solution moves up
- ↓ drop of blue solution moves down
- ↔ drop of blue solution remains at the same level

**Fig. 1.2**

[1]

You are provided with the materials shown in Table 1.1.

**Table 1.1**

| labelled | contents                                   | hazard        | volume/cm <sup>3</sup> |
|----------|--|---------------|------------------------|
| <b>S</b> | 1.00 mol dm <sup>-3</sup> sucrose solution | none          | 150                    |
| <b>W</b> | distilled water                            | none          | 250                    |
| <b>P</b> | 5 potato cylinders                         | none          | –                      |
| <b>M</b> | blue dye                                   | health hazard | 20                     |

If **M** comes into contact with your skin, wash it off immediately under cold water.

It is recommended that you wear suitable eye protection.

You will need to carry out a **serial** dilution of the 1.00 mol dm<sup>-3</sup> sucrose solution, **S**, to reduce the concentration by **half** between each successive dilution.

You will need to prepare **four** concentrations of sucrose solution in addition to the 1.00 mol dm<sup>-3</sup> sucrose solution, **S**.

After the serial dilution is completed, you will need to have 50 cm<sup>3</sup> of each concentration available to use.

- (ii) Complete Fig. 1.3 to show how you will prepare your serial dilution in the beakers provided.

Fig. 1.3 shows the first two beakers you will use to make your serial dilution. You will need to draw **three** additional beakers.

For each beaker, add arrows and labels to show:

- the volume of sucrose solution transferred
- the volume of distilled water, **W**, added.

Under each beaker, state the concentration of the sucrose solution.

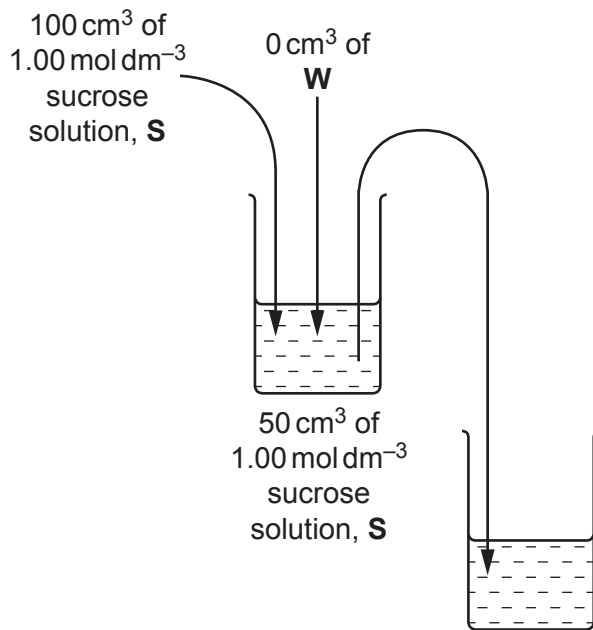

Fig. 1.3

[3]

Carry out step 1 to step 22.

- step 1 Prepare the concentrations of sucrose solution, as decided in **(a)(ii)**, in the beakers provided.

step 2 Label five large test-tubes with the concentrations of sucrose solution prepared in step 1, including  $1.00 \text{ mol dm}^{-3}$ .

step 3 Put the five potato cylinders onto a white tile.

(iii) The potato cylinders all have the same diameter.

State the method that you will use to standardise the surface area of all five potato cylinders.

.....  
..... [1]

step 4 Carry out the method stated in (a)(iii) for each of the five potato cylinders.

step 5 Cut one of the potato cylinders into eight pieces of approximately the same length.

step 6 Put the eight pieces of potato into one of the large test-tubes labelled in step 2.

step 7 Repeat step 5 and step 6 for the four other potato cylinders so that there are eight pieces of potato in each of the large test-tubes labelled in step 2.

You will put sucrose solution into each large test-tube to just cover the eight pieces of potato.

You will need to standardise the volume of sucrose solution put into each of the large test-tubes.

(iv) State the volume of sucrose solution you will use to just cover the eight pieces of potato in each large test-tube.

volume = ..... [1]

step 8 Put each concentration of sucrose solution prepared in step 1, including  $1.00 \text{ mol dm}^{-3}$ , into the appropriately labelled large test-tube. For each large test-tube, use the volume of sucrose solution stated in (a)(iv) to cover the potato pieces.

step 9 Leave the pieces of potato in the sucrose solutions for 15 minutes. While you are waiting, continue with step 10 to step 13.

step 10 Label five small test-tubes with the concentrations of sucrose solution that you have used in step 8.

step 11 Put a mark 5 cm from the bottom of each of the small test-tubes, as shown in Fig. 1.4.

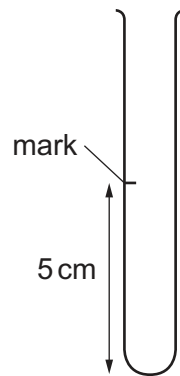

**Fig. 1.4**

- step 12 Put  $15\text{ cm}^3$  of  $1.00\text{ mol dm}^{-3}$  sucrose solution into the appropriately labelled small test-tube.
- step 13 Repeat step 12 with each of the other concentrations of sucrose solution.
- step 14 After leaving the pieces of potato for 15 minutes in step 9, put  $1\text{ cm}^3$  of the blue dye, **M**, into each of the large test-tubes containing eight pieces of potato in sucrose solution.
- step 15 Swirl the contents of the large test-tubes to mix **M** with the sucrose solution. The blue dye may not mix in completely. This will not affect the results.

step 16 Use a pipette to remove a sample of the blue solution from around the pieces of potato in the large test-tube to which  $1.00 \text{ mol dm}^{-3}$  sucrose solution had been added.

Throughout step 17 to step 20, the pipette must be held still so that its position does not change. Drops can then be released and observed without disturbing the sucrose solution.

step 17 Put the end of the pipette into the small test-tube containing  $1.00 \text{ mol dm}^{-3}$  sucrose solution.

The end of the pipette should be level with the mark on the small test-tube, as shown in Fig. 1.5.

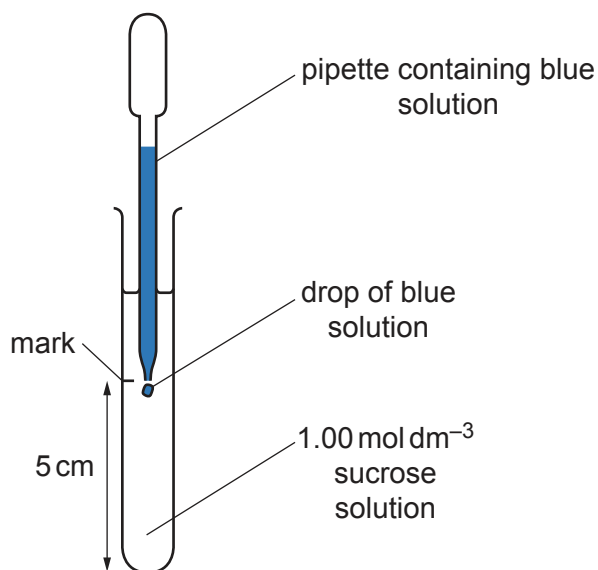

**Fig. 1.5**

step 18 Keeping the end of the pipette as still as possible, release a drop of the blue solution from the pipette.

step 19 Observe the direction **and** speed of movement of the drop of blue solution.

step 20 Repeat step 18 and step 19 two more times.

step 21 Record your observations in **(a)(v)**.

step 22 Repeat step 16 to step 21 for the other concentrations of sucrose solution. In step 17 and step 18, make sure that drops of the blue solution from each large test-tube are released into the small test-tubes labelled with the same concentration of sucrose.



- (v) Record, in an appropriate table, your observations of the direction **and** speed of movement of the drops.

You may use the same symbols as in (a)(i) to show the direction of movement of the drops.

[6]

- (vi) Using your results in (a)(v), estimate the concentration of sucrose solution that has a water potential equal to the water potential of the potato cells.

concentration of sucrose solution = ..... mol dm<sup>-3</sup> [1]

- (vii) Describe how you would modify the procedure to obtain a more accurate estimate in (a)(vi).

.....

.....

.....

.....

..... [2]

(viii) Describe the movement of water molecules when the water potential of the sucrose solution surrounding the piece of potato is the same as the water potential of the potato cells.

.....  
.....  
.....  
.....  
..... [2]

(ix) State **one** source of error in the procedure that you have carried out.

.....  
.....  
..... [1]

**Question 1 continues on page 12**

(b) A student investigated the effect of different concentrations of sodium chloride solution on the movement of water into dialysis (Visking) tubing.

- One end of a piece of dialysis tubing was sealed and  $10\text{ cm}^3$  of  $0.8\text{ mol dm}^{-3}$  sodium chloride solution was put into the tubing. The open end was then sealed to form a bag.
- This was repeated for four other concentrations of sodium chloride solution.
- Each bag was weighed, immersed in distilled water and left for 1 hour, as shown in Fig. 1.6.

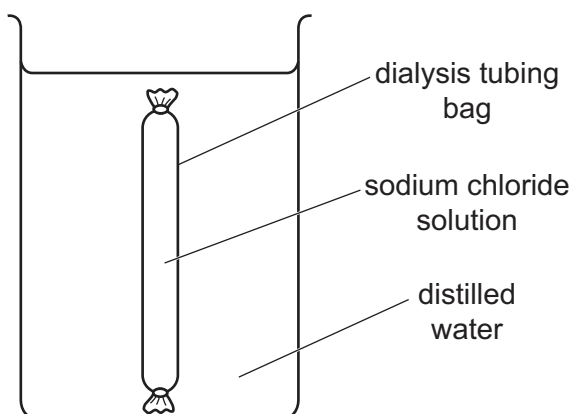

Fig. 1.6

- After 1 hour, each bag was taken out of its beaker, wiped with a paper towel to remove water on the outside and reweighed.
- The student then calculated the percentage change in mass for each bag.

The results are shown in Table 1.2.

Table 1.2

| concentration of sodium chloride solution / $\text{mol dm}^{-3}$ | percentage change in mass |
|--|---------------------------|
| 0.0  | 0                         |
| 0.2  | +5.4                      |
| 0.4  | +7.6                      |
| 0.6  | +8.7                      |
| 0.8  | +9.5                      |

- (i) Plot a graph of the data shown in Table 1.2 on the grid in Fig. 1.7.

Use a sharp pencil.

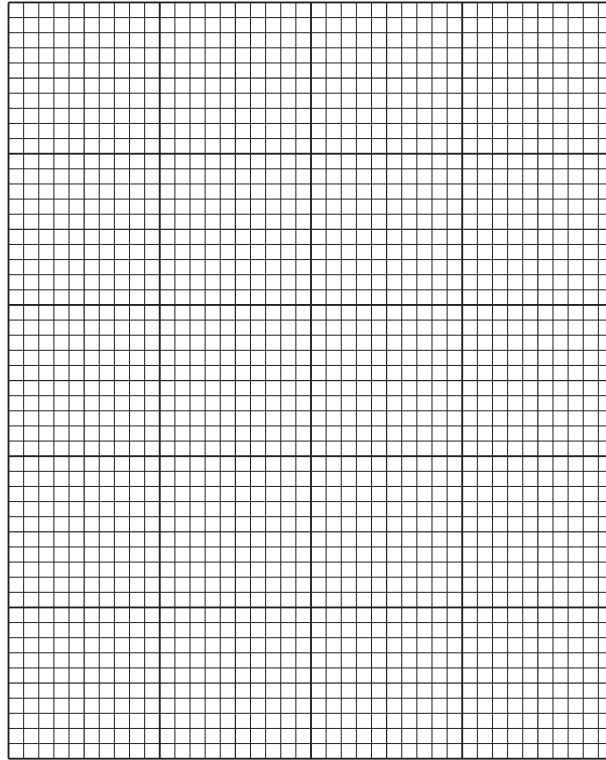

Fig. 1.7

[4]

- (ii) Use your graph to estimate the percentage change in mass when the sodium chloride concentration is  $0.3 \text{ mol dm}^{-3}$ .

percentage change in mass = ..... [1]

[Total: 23]

2 **J1** is a slide of a stained transverse section through a plant stem.

- (a) (i) Draw a large plan diagram of the region of the stem on slide **J1** indicated by the shaded area in Fig. 2.1. Use a sharp pencil.

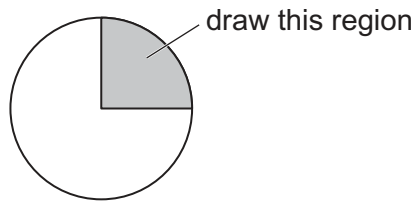

**Fig. 2.1**

Use **one** ruled label line and label to identify the xylem.

[5]

(ii) Observe one vascular bundle in the stem on slide **J1**.

Select four adjacent touching xylem vessel elements that are arranged in a line.

Each of these four xylem vessel elements must touch at least one other.

- Make a large drawing of the line of **four** xylem vessel elements that you have selected.
- Use **one** ruled label line and label to identify **one** lumen.

[5]

(b) Fig. 2.2 is a photomicrograph of a transverse section through a stem of a different type of plant.

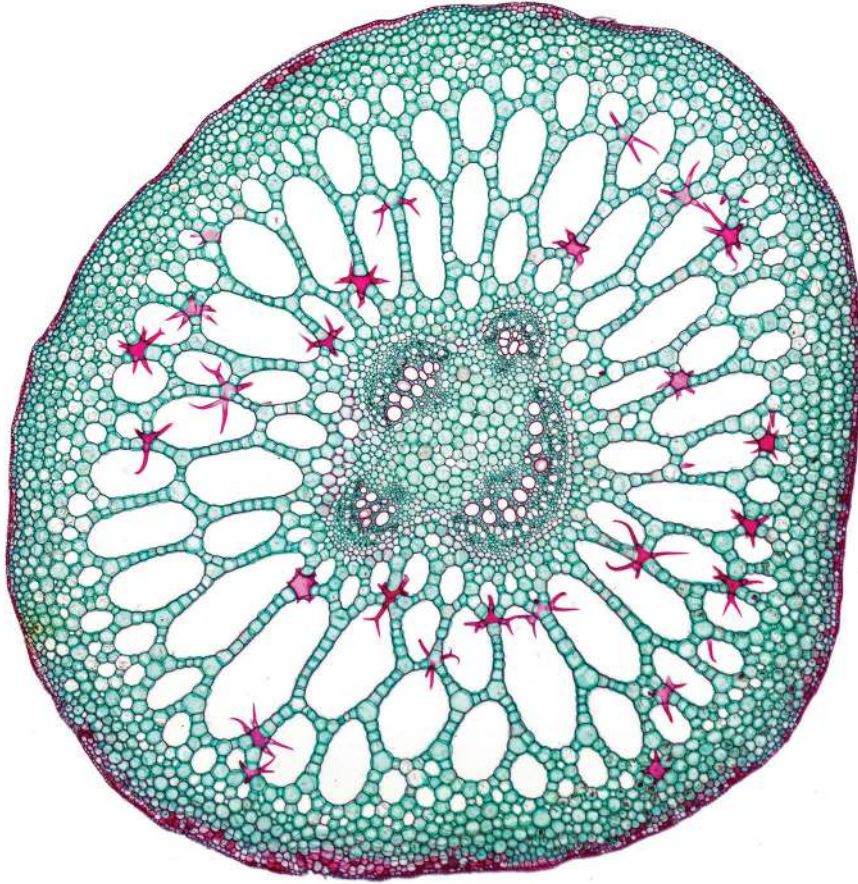

Fig. 2.2



Identify **three** observable differences, other than size and colour, between the stem on slide **J1** and the stem in Fig. 2.2.

Record these **three** observable differences in Table 2.1.

**Table 2.1**

| feature | slide J1 | Fig. 2.2 |
|---------|----------|----------|
|         |          |          |

[3]

(c) Fig. 2.3 is the same photomicrograph as the transverse section of the stem shown in Fig. 2.2.

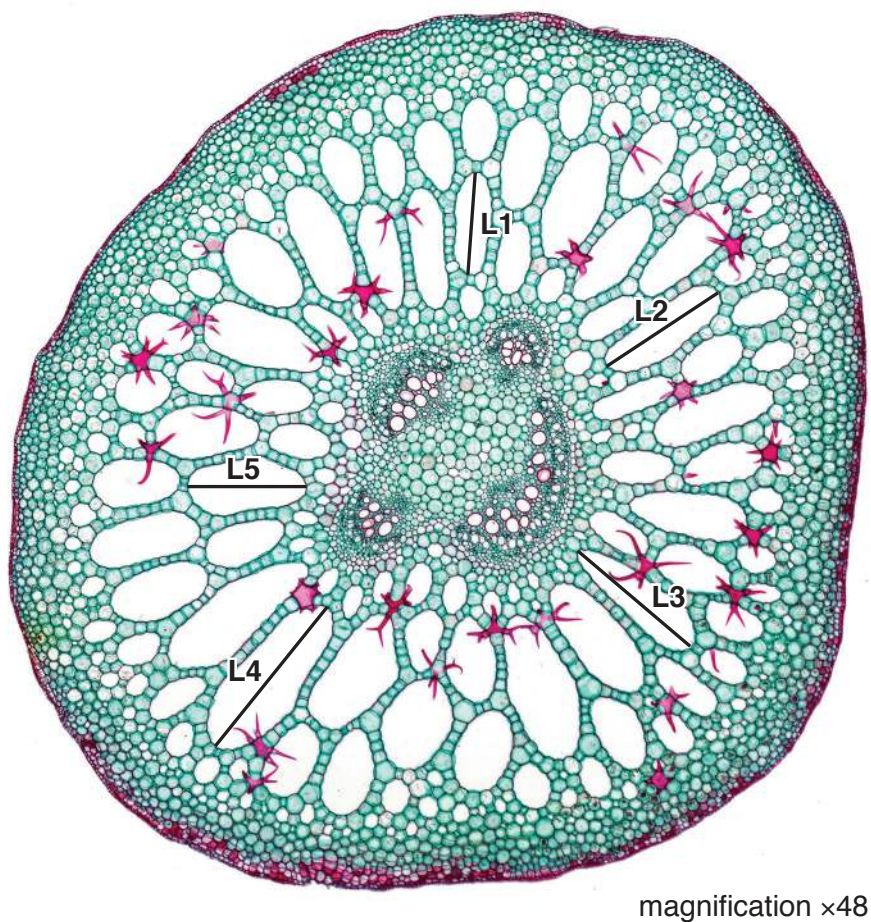

**Fig. 2.3**

- (i) Measure the lengths of the lines **L1**, **L2**, **L3**, **L4** and **L5** in Fig. 2.3. The lines have been drawn along the lengths of five air spaces.

Calculate the mean length of the five lines.

Show your working.

length of **L1** = .....

length of **L2** = .....

length of **L3** = .....

length of **L4** = .....

length of **L5** = .....

mean length of lines = .....

[2]

- (ii) Using the magnification stated in Fig. 2.3, calculate the actual mean length of the air spaces labelled **L1**, **L2**, **L3**, **L4** and **L5**.

Show your working.

actual mean length = ..... [2]

[Total: 17]

**BLANK PAGE**

---

Permission to reproduce items where third-party owned material protected by copyright is included has been sought and cleared where possible. Every reasonable effort has been made by the publisher (UCLES) to trace copyright holders, but if any items requiring clearance have unwittingly been included, the publisher will be pleased to make amends at the earliest possible opportunity.

To avoid the issue of disclosure of answer-related information to candidates, all copyright acknowledgements are reproduced online in the Cambridge Assessment International Education Copyright Acknowledgements Booklet. This is produced for each series of examinations and is freely available to download at [www.cambridgeinternational.org](http://www.cambridgeinternational.org) after the live examination series.

Cambridge Assessment International Education is part of Cambridge Assessment. Cambridge Assessment is the brand name of the University of Cambridge Local Examinations Syndicate (UCLES), which is a department of the University of Cambridge.